

heinrich

Grip-Master VISES

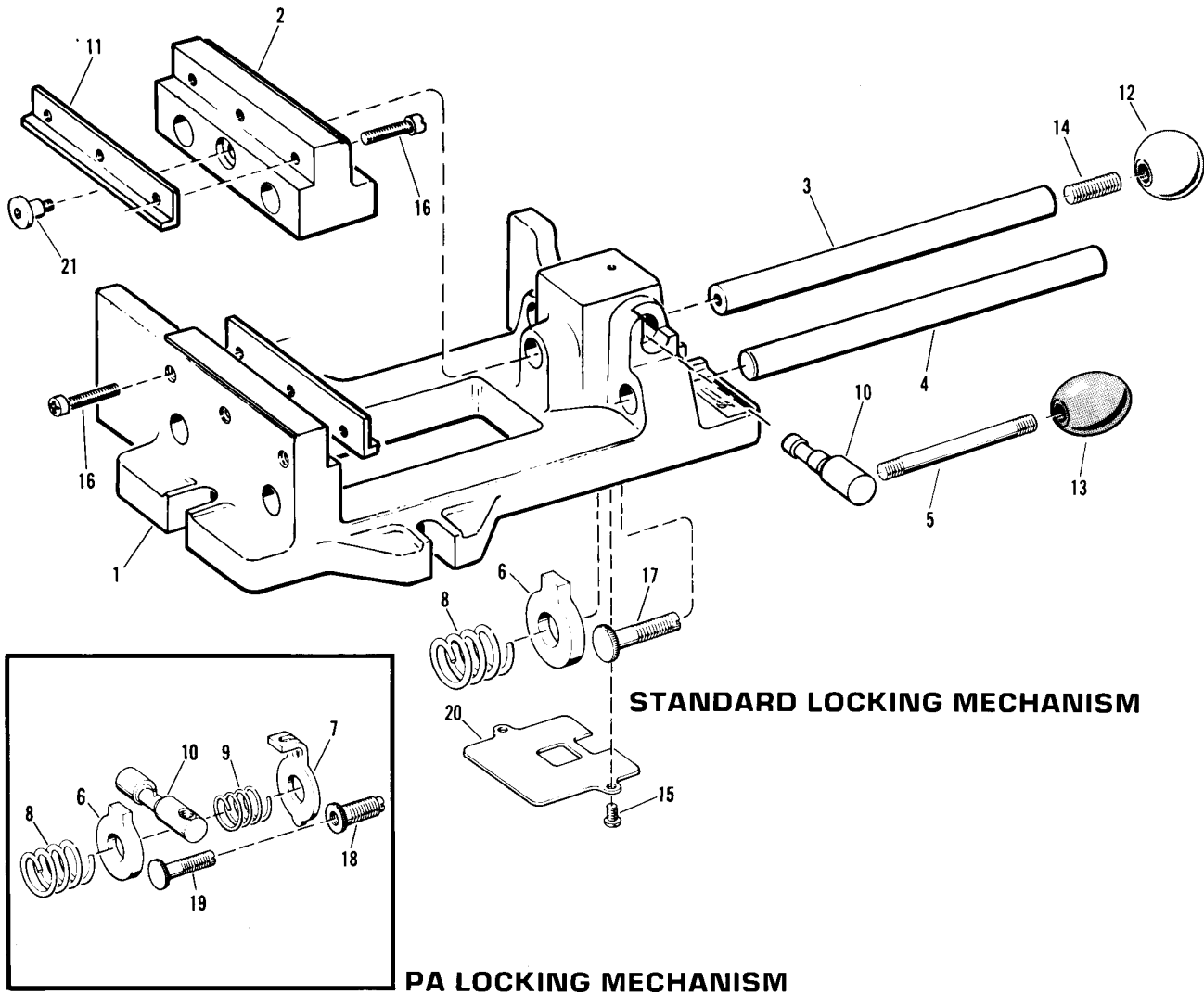

OPERATION:

Grip-Master units are adjusted for proper holding pressure at the time of assembly. Increased pressure can be obtained by a slight counter-clockwise turn of the adjusting screw (after first loosening the cover plate). Decrease pressure by a clockwise turn of the adjusting screw. The amount of turn necessary can be determined by the results obtained. The maximum pressure setting is not necessary for adequate holding power. If it is difficult to depress the locking lever, the setting is on the heavy side. When just normal hand pressure is required to lower the lever to horizontal position, this is the proper setting of the adjusting screw. It is best when re-setting the locking mechanism to adjust to absolute maximum, then reduce pressure down to about middle range for ease of operation. Turning too far in either direction will cause the center bar to lock. For maximum machining accuracy, clamp vise to the work table using the two side lugs.

MAINTENANCE:

The locking mechanism of Grip-Master units must be oiled occasionally in the oil hole provided therefor. Keep bars and locking mechanism free from dirt and chips.

If a Grip-Master unit becomes inoperable, disassemble the locking mechanism in this manner:

1. To remove center bar (3) of a vise, place handle in locked position and remove the shoulder screw which attaches it to the movable jaw. (On models prior to 1958, the center bar was press fit into the movable jaw casting; bar can be removed by inserting a 1/4" pin in the knock-out hole in the movable jaw casting.)
2. Place handle lever (5) in vertical position.
3. Remove screws and cover plate (20).
4. Remove spring pressure on locking ring (6) by turning adjusting screw (17) counter-clockwise.
5. All locking mechanism parts can then be removed.

Clean and check each part for wear or damage. Replacement parts are available for immediate shipment from factory stock, or you may order through your local Heinrich distributor.

REASSEMBLE all parts of **Standard Locking Mechanisms** as per the exploded view, setting adjusting screw to desired (Cont. on next page)

Index No.	Part Name	MODEL NUMBER							
		3-SV 3-TS* 3-PA**		4-GM 4-TS* 4-GMPA**		6-SV 6-PA**		8-SV 8-PA**	
		Part No.	Price	Part No.	Price	Part No.	Price	Part No.	Price
1	Body Casting (Note 1)	3-SV	--	4-GM	--	6-SV	--	8-SV	--
1	Body Casting (Note 1)	3-TS*	--	4-TS*	--	--	--	--	--
2	Jaw Casting	3-J	\$32.67	4-J	\$45.38	6-J	\$58.99	8-J	\$86.21
3	Center Bar	313	18.15	GM-413	25.71	613	33.28	813	46.89
4	Guide Bar (2 required)	314	10.59	414	15.13	614	25.71	814	34.79
5	Handle	GM-3415	3.63	GM-3415	3.63	6815	5.66	6815	5.66
5	Handle	TS-3415*	5.66	TS-3415*	5.66	--	--	--	--
6	Locking Ring	SV-3416 (1/2" Hole)	23.23	GM-416 (5/8" Hole)	27.59	SV-6816 (3/4" Hole)	30.49	SV-6816 (3/4" Hole)	30.49
7	Holding Ring	PA-3416**	18.88	GMPA-416**	26.14	PA-6816**	27.59	PA-6816**	27.59
8	Spring, Lock	GM-417	8.71	GM-417	8.71	6817	10.16	6817	10.16
9	Spring, Holding	PA-3417**	11.62	GMPA-417**	10.16	PA-6817**	8.71	PA-6817**	8.71
10	Crank	GM-3418	15.97	GM-3418	15.97	GM-6818	30.49	GM-6818	30.49
10	Crank	TS-3418*	20.33	TS-3418*	20.33	--	--	--	--
10	Crank, with 1/8" Rollpin	GMPA-3418**	21.05	GMPA-3418**	21.05	GMPA-6818**	31.94	GMPA-6818**	31.94
11	Jaw Inserts, regular (set of 2)	319	15.97	419	18.88	619	30.49	819	39.20
11	Jaw Inserts, Hardened (set of 2)	319H	21.78	419H	27.59	619H	42.11	819H	50.82
12	Knob, Black -- 1" Dia., 1/4-20 thread	SV-3421(*)	3.34	--	--	--	--	--	--
12	Knob, Red -- 1" Dia., 1/4-20 thread	RSV-3421**	3.48	--	--	--	--	--	--
12	Knob, Black -- 1 1/2" Dia., 3/8-24 thread	--	--	SV-6821(*)	3.48	SV-6821	3.48	SV-6821	3.48
12	Knob, Red -- 1 1/2" Dia., 3/8-24 thread	--	--	RSV-6821**	6.97	RSV-6821**	6.97	RSV-6821**	6.97
13	Knob, Black -- 1 1/8" x 1 7/16" oval, 3/8-16 thread	OA-3421	3.48	OA-3421	3.48	--	--	--	--
13	Knob, Black -- 1" Dia., 1/4-20 thread	SV-3421*	3.34	SV-3421*	3.34	--	--	--	--
13	Knob, Red -- 1 1/8" x 1 7/16" oval, 3/8-16 thread	ROA-3421**	6.10	ROA-3421**	6.10	--	--	--	--
13	Knob, Black -- 1 1/2" Dia., 3/8-24 thread	--	--	--	--	SV-6821	3.48	SV-6821	3.48
13	Knob, Red -- 1 1/2" Dia., 3/8-24 thread	--	--	--	--	RSV-6821**	6.97	RSV-6821**	6.97
14	Stud	3423	1.89	6823	2.03	6823	2.03	6823	2.03
15	Screw -- 10-32 x 1/4 (2 required)	27	0.44	27	0.44	27	0.44	27	0.44
16	Screw -- 1/4-20 x 5/8	(2) 30-5/8	1.67	--	--	--	--	--	--
16	Screw -- 1/4-20 x 3/4	(2) 30-3/4	1.67	(6) 30-3/4	1.67	(6) 30-3/4	1.67	(6) 30-3/4	1.67
17	Adjusting Screw	SV-31	7.26	SV-31	7.26	SV-31	7.26	SV-31	7.26
18	Adjusting Screw -- Female	PA-32**	8.71	PA-32**	8.71	PA-32**	8.71	PA-32**	8.71
19	Adjusting Screw -- Male	PA-33**	8.71	PA-33**	8.71	PA-33**	8.71	PA-33**	8.71
20	Cover Plate	3437	3.12	3437	3.12	6837	5.30	6837	5.30
21	Shoulder Screw	39	4.21	39	4.21	39	4.21	39	4.21

Note 1. Price not shown, as replacement body castings are not available. View shown is 4-GM with side extension. Models 3-SV, 6-SV and 8-SV do not have side extensions. 3-TS and 4-TS have both sides ground at right angles to jaw inserts.

WHEN ORDERING PARTS, INDICATE PART NUMBER, MODEL NUMBER AND PRICE.

(Cont. from prev. page) pressure before replacing locking plate. To assemble **Pumping Action "PA" Locking Mechanisms**, the following steps must be carefully followed:

1. Insert crank (10), keeping handle lever (5) in vertical position during entire assembly.
2. Insert rear portion of adjusting screw (18), screwing same in as far as it will go.
3. Place the holding ring (7) behind crank so that the pin extending from the crank fits into the slot of the holding ring.
4. Insert center bar (3) through the holding ring far enough so that the holding spring (9) can be slipped on.
5. Insert front portion of the adjusting screw (19) as far as it will go.

6. Insert locking ring (6) and push center bar through same.
7. Insert locking spring (8), locating same correctly in relation to the center hole.
8. Adjust both adjusting screws until the rear portion (18) makes contact with the holding ring and the front portion (19) makes contact with the locking ring.
9. Push center bar through entire unit.
10. Turn adjusting screw front portion (19) a 3/4 turn clockwise, and adjust rear portion (18) until the bar moves freely – making sure that the handle lever is in vertical position against stop.
11. Adjust forward portion of adjusting screw (19) until desired pressure is obtained.